

Pressure control panel BE55/56-1-VCR

spectron pur



BE55-1-VCR

Product features

- Pressure control panel for corrosive gases and gas mixtures with corrosive components from grade 6.0
- Single- or dual-stage version
- High control accuracy
- Pressure regulator with tied diaphragm
- Orbital welded VCR-connections
- Pre-filter
- Panel can be evacuated
- Burst disc
- High pressure waste gas valve (HPV)
- Inlet process gas valve (HPI)
- Stainless steel valves for manual or automatic (pneumatic) shut-off
- 100 % Helium leak tested
- Assembly in clean room class ISO 5.0

Technical data

Inlet pressure P_1	max. 300 bar
Outlet pressure P_2	max. 1,5 / 4 / 10 bar
Materials	
Body:	Stainless steel 1.4404
Diaphragms:	Hastelloy C276
Other gas wetted parts:	Stainless steel 1.4404
Sealings	
BE55 ($P_1 \leq 50$ bar) or 2. stage BE56:	PTFE
BE55 ($P_1 > 50$ bar) or 1. stage BE56 and valves:	PCTFE or PVDF
Surface roughness (gas wetted areas)	$R_{a,max} \leq 0,25 \mu\text{m}$
Temperature range	-20°C to +60°C
Leak rate	
to atmosphere:	$\leq 10^{-9}$ mbar l/s He
via valve seat:	$\leq 10^{-6}$ mbar l/s He
c_v-value	$c_v = 0,24$ ($k_v = 0,2$)
Weight	4,1 / 4,6 kg
Connectors	
Inlet:	VCR-male
Outlets:	VCR-female

Pressure control panel BE55/56-1-VCR



Dimensions

BE55-1

BE56-1

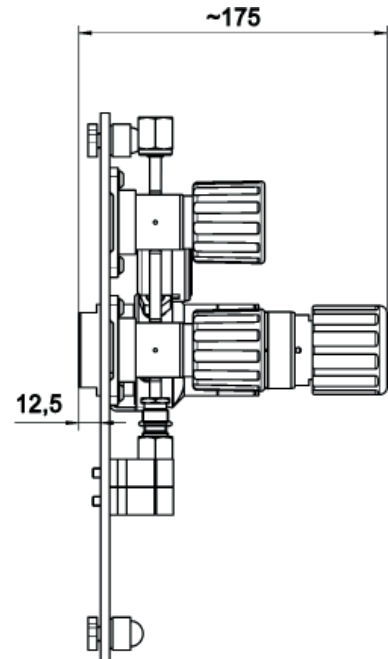
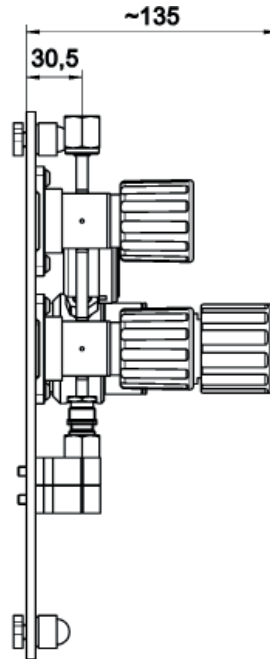
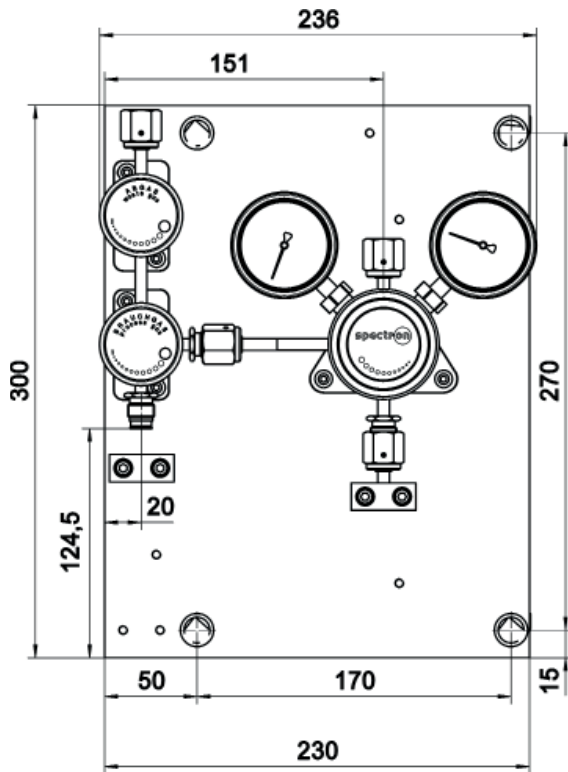

Ordering information: Pressure control panel BE55/56-1-VCR

BE55-1-VCR - 300 - 10 - V - V - M - M - BD - Gas

Pressure regulator*

- 0 w/o regulator upon request
- 55 1-stage pressure regulator
- 56 2-stage pressure regulator

Inlet pressure P_1^*

- 10 max. 10 bar
- 20 max. 20 bar
- 50 max. 50 bar
- 100 max. 100 bar
- 200 max. 200 bar
- 300 max. 300 bar

Outlet pressure P_2^*

- 1,5 max. 1,5 bar
- 4 max. 4 bar
- 10 max. 10 bar

* 55 $P_1 \leq 50 \text{ bar} \rightarrow P_2: 1,5 / 4 \text{ bar}$
 $P_1 > 50 \text{ bar} \rightarrow P_2: 10 \text{ bar}$

56 $P_1 \geq 50 \text{ bar}$

Downstream protection

- BD burst disc
- BDM burst disc + monitoring

Outlet pressure indication

Inlet pressure indication

- M pressure gauge
- K contact pressure gauge
- PT pressure transmitter

High pressure waste gas HPV

Process gas inlet HPI

- V valve (manual)
- VQ 1/4-turn valve
- VP pneumatic valve (NC)